



# TYPHOON INTAKE SYSTEMS

## INSTALLATION INSTRUCTIONS

### 69-4515 CHEVROLET 2005-10 COBALT L4-2.2L

NOTE: C.A.R.B. E.O.#D-269-32 APPLIES ONLY TO 2005-06 MODEL YEARS ONLY

#### TOOLS NEEDED:

- 1/2" wrench
- 10mm socket
- 17mm socket
- 10mm wrench
- extension
- flat blade screwdriver
- pliers
- ratchet
- t-30 torx socket

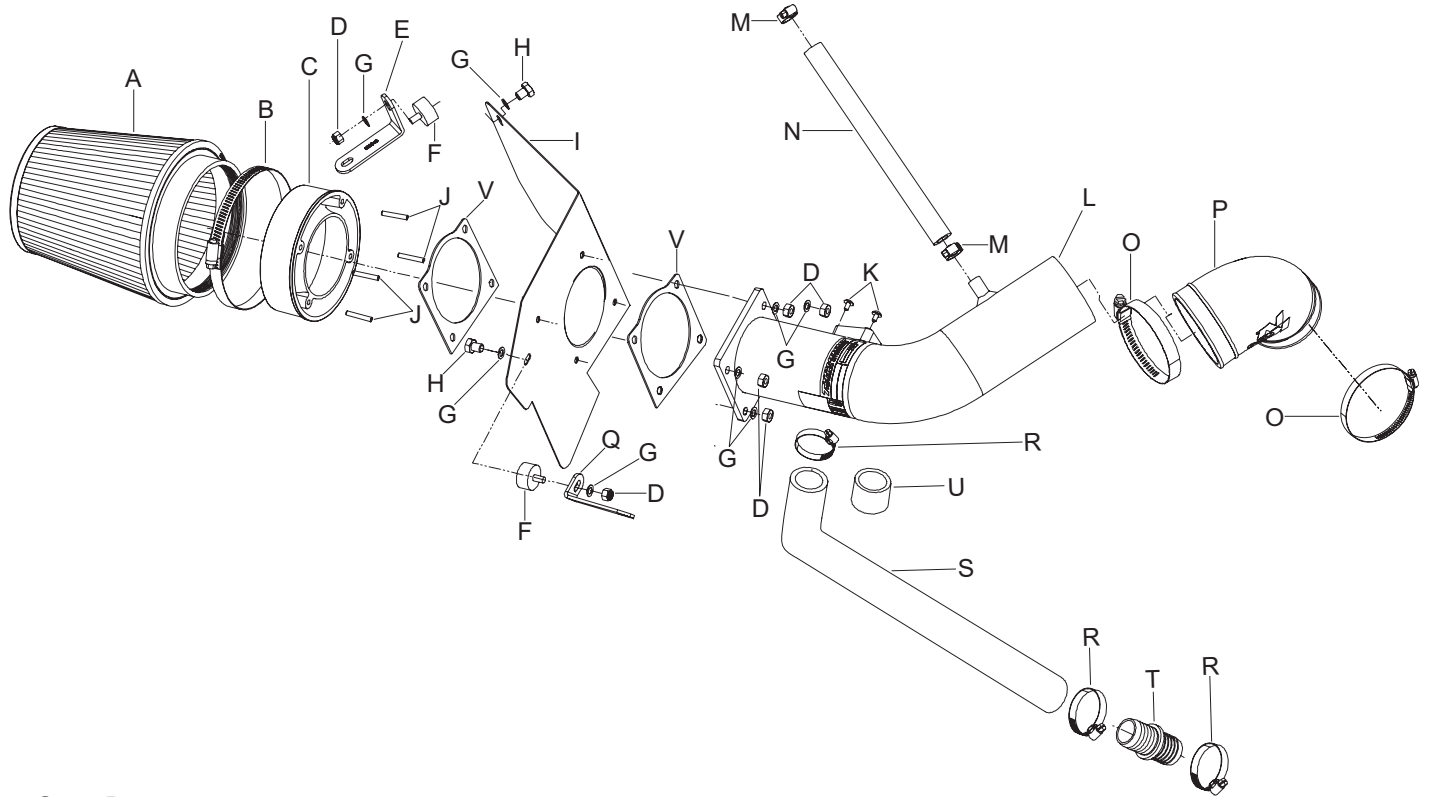

#### PARTS LIST:

Description	Qty.	Part #	Description	Qty.	Part #	Description	Qty.	Part #
A Air Filter	1	RU-5147	I Heat Shield	1	07334	Q Bracket 69-4515, L, Stl., FB/PC	1	020001
B Hose Clamp #80	1	08694	J Stud; 6mm-1.00 x 35mm L, SS	4	08220	R Hose Clamp #16	3	08413
C Filter Adapter - #350	1	21510	K Bolt M4 x .7 x 8mm, Button Head, SS	2	07741	S Hose; 1"ID x 4-1/2"L, Black Silicone	1	08479
D Nut 6mm Nylock, SS	6	07553	L Tube 2-3/4"OD x 20"L, Al.	1	27508-1TS	T Vent, Strt.; 1" x 1", Barbed, Plastic	1	08296
E Bracket "L" Small, Stl., FK/PC	1	010031	M Hose Clamp #6 Mini	2	08407	U Caplug; 15/16" ID, 3/4" L, Blk.	1	08246
F Stud Rubber Mnt., M/F	2	070228	N Hose 1/2"ID x 9"L, Black Silicone	1	08401	V Gasket; 63-1034, 1/16" Neoprene	2	09202
G Washer 6mm Wave, SS	8	08277	O Hose Clamp #44 SS	2	08560			
H Bolt 6mm-1.00 x 12mm Hex	2	07863	P Hose 69-4515, 2-3/4"ID to 3" ID Elbow, Blk	1	084087			

**NOTE: FAILURE TO FOLLOW INSTALLATION INSTRUCTIONS AND NOT USING THE PROVIDED HARDWARE MAY DAMAGE THE INTAKE TUBE, THROTTLE BODY AND ENGINE.**

#### TO START:

1. Turn off the ignition and disconnect the negative battery cable.  
**NOTE: Disconnecting the negative battery cable erases pre-programmed electronic memories. Write down all memory settings before disconnecting the negative battery cable. Some radios will require an anti-theft coded to be entered after the battery is reconnected. The anti-theft code is typically supplied with your owner's manual. In the event your vehicles' anti-theft code cannot be recovered, contact an authorized dealership to obtain your vehicles anti-theft code.**



2. Remove the oil filler cap as shown.

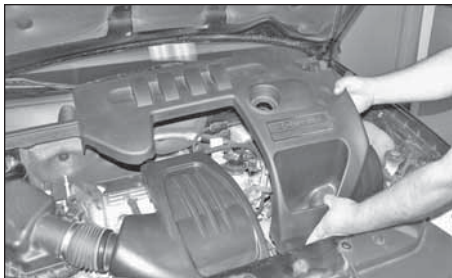

3. Pull firmly upwards to release the engine cover and remove from vehicle.

**NOTE: Replace oil filler cap.**

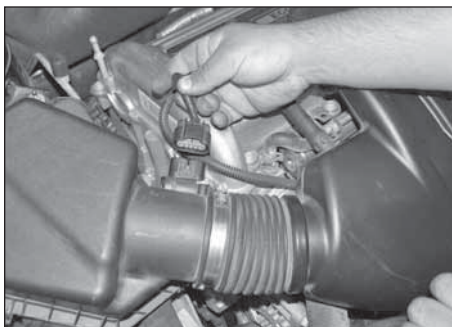

4. Disconnect the mass air sensor electrical connection.

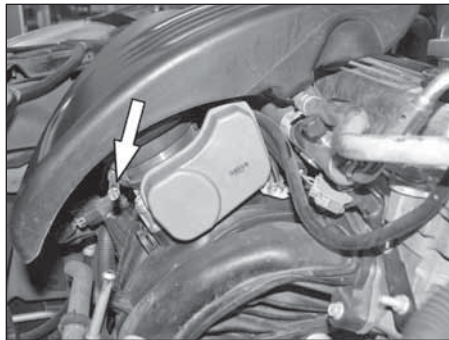

5. Loosen the hose clamp at the throttle body.

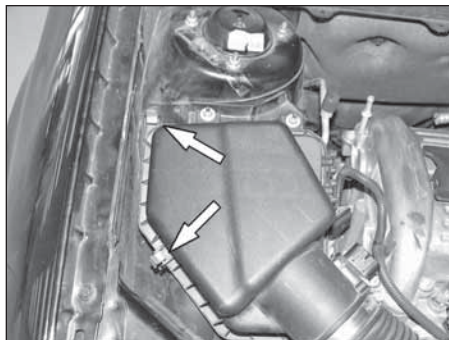

6. Unclip the air box fastening clips.

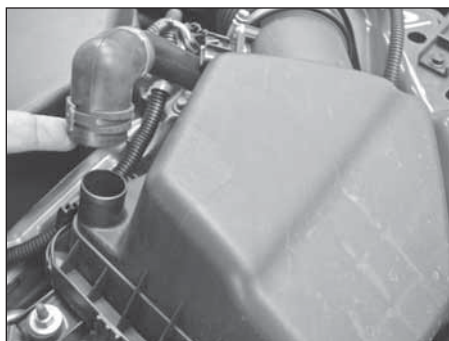

6a. On 2006 and later models, release the clamp and disconnect the air injection pump hose from the air box.

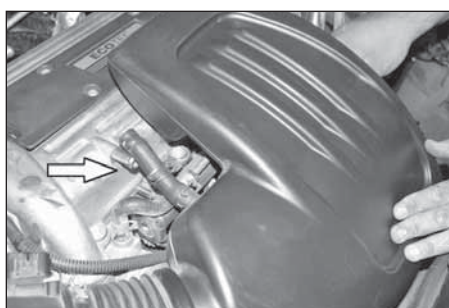

7. Release clamp and remove crankcase vent hose.



8. Unclip air box mounting clip.



9. Lift firmly upwards and remove air box from vehicle.

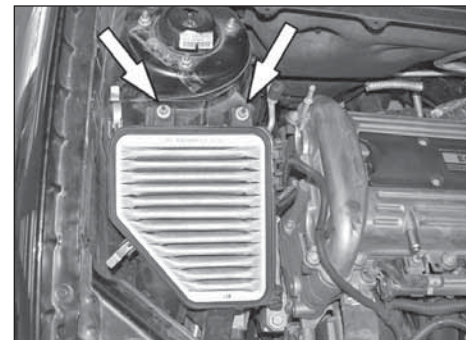

10. Loosen and remove the two air box retaining nuts then remove the air box from vehicle.  
**NOTE: K&N Engineering, Inc., recommends that customers do not discard factory air intake.**

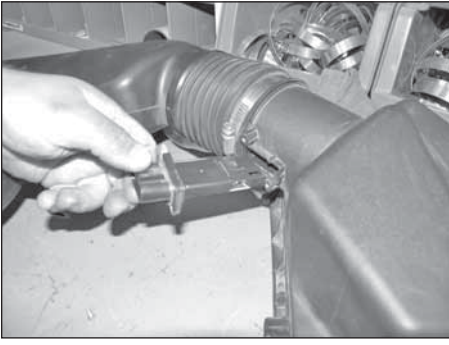

11. Remove mass air sensor from stock intake tube.

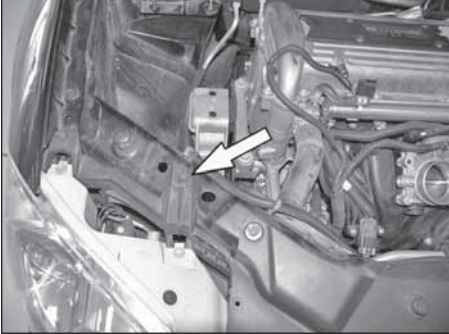

12. Remove the head light mounting bolt and retain as it will be reused.

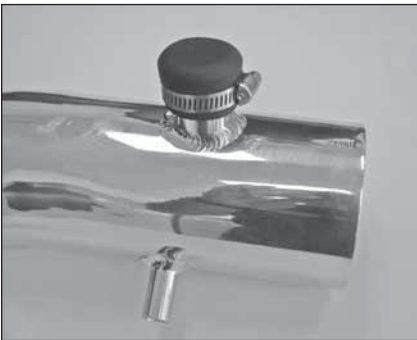

13. On '05 models, install the supplied cap plug onto the 1" diameter vent fitting on the intake tube and secure it with the provided hose clamp.

**NOTE: You may now proceed to step #17.**

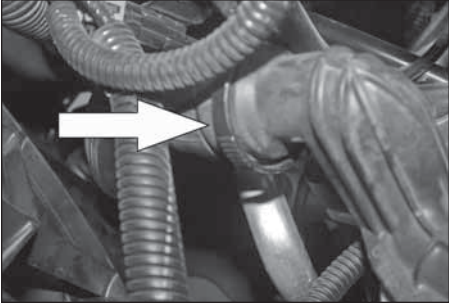

14. On 2006 and later models, disconnect the air injection pump plastic hard line from the air injection rubber hose.



15. On 2006 and later model year vehicles, install the 1.0" hose mender into the provided air injection hose (08479) and secure with the provided hose clamp.

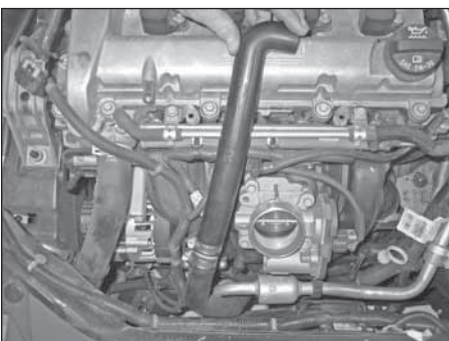

16. On 2006 and later model year vehicles, attach the air injection hose assembly to the factory rubber air injection hose and secure with the provided hose clamp.

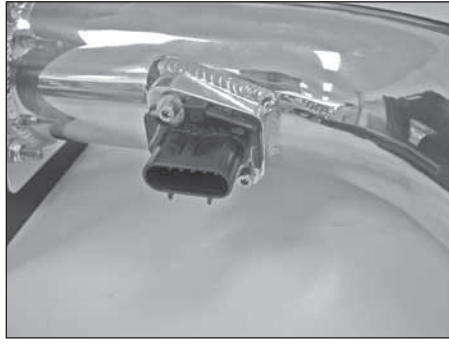

17. Install the mass air sensor onto the K&N® intake tube with provided hardware.



18. With the provided hardware, assemble the studs onto adapter as shown.

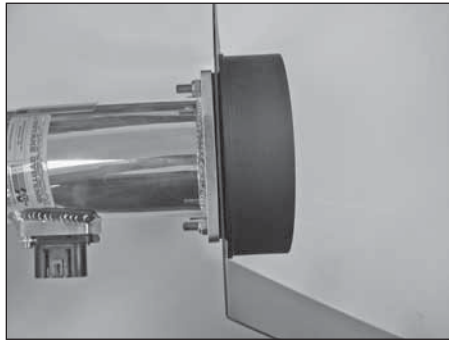

19. With the provided hardware, assemble the filter adaptor and gaskets onto the heat shield and intake tube as shown.



20. Install the silicone hose and hose clamps onto the intake tube as shown.

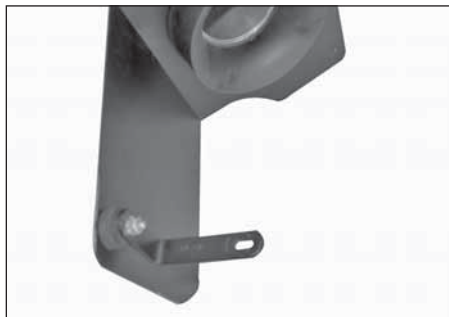

21. Install the rubber mounted stud and small "L" bracket onto the heat shield using supplied hardware. Do not tighten completely at this time.

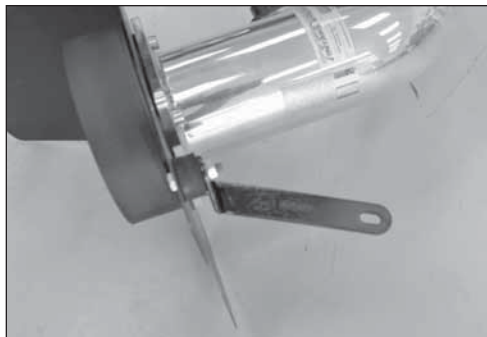

22. Install the rubber mounted stud and "L" bracket onto the heat shield with the provided hardware. Do not tighten completely at this time.

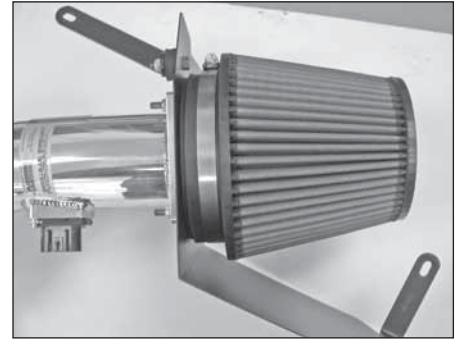

23. Secure the K&N® air filter onto the filter adapter and secure with provided hose clamp.

**NOTE: Drycharger® filter wrap; part # RU-5147DK is available to purchase separately. To learn more about Drycharger® filter wraps or look up color availability please visit <http://www.knfilters.com>**

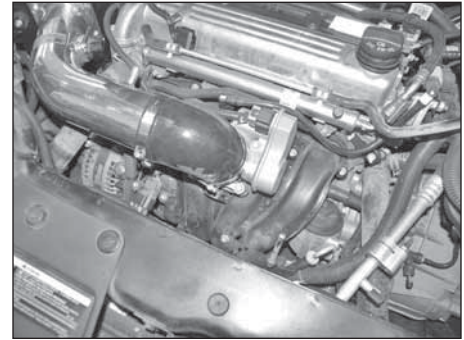

24. Install the intake tube assembly, attaching the silicone hose onto the throttle body as shown.

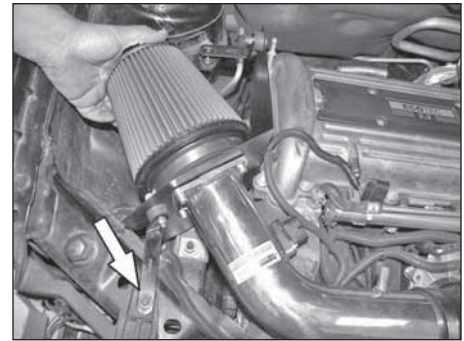

25. Align the heat shield bracket onto the head light mounting hole and secure it with stock bolt from step #12.



26. Align the heat shield bracket onto the stock air box mounting stud and secure it with the stock bolt from step #10.



27. On '06 models attach the air injection pump hose to the 1" diameter vent fitting on the intake tube and secure with the provided hose clamp.



28. Assemble the supplied silicone hose and two mini clamps as shown.

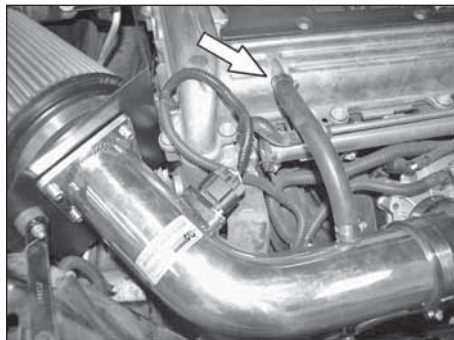

29. Install the silicone hose onto the intake tube vent and onto the crankcase vent line as shown. Tighten hose clamps completely.

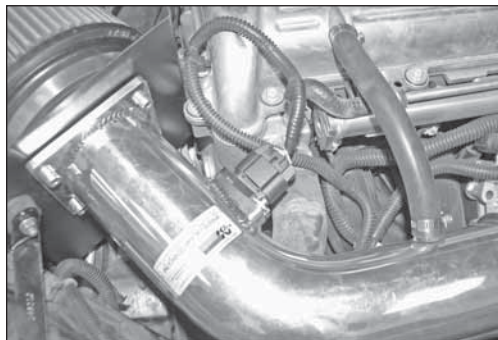

30. Re-connect the mass air sensor electrical connection as shown.

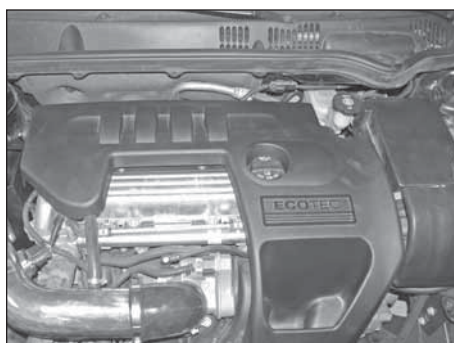

31. Remove oil filler cap so the engine cover can be reinstalled. Reinstall the oil filler cap.

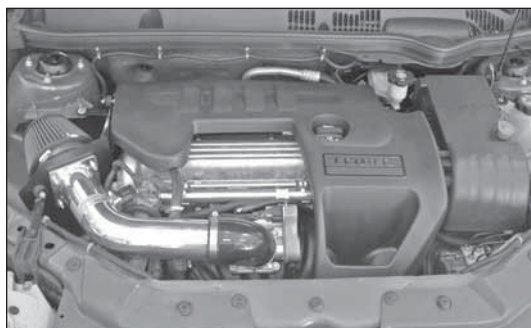

32. Reconnect the vehicle's negative battery cable. Double check to make sure everything is tight and properly positioned before starting the vehicle.

33. The C.A.R.B. exemption sticker, (attached), must be visible under the hood, so the emissions inspector can see it when the vehicle is required to be tested for emissions. California requires testing every two years, other states may vary.

34. It will be necessary for all K&N® high flow intake systems to be checked periodically for realignment, clearance and tightening of all connections. Failure to follow the above instructions or proper maintenance may void warranty.

#### ROAD TESTING:

1. Start the engine with the transmission in neutral or park, and the parking brake engaged. Listen for air leaks or odd noises. For air leaks secure hoses and connections. For odd noises, find cause and repair before proceeding. This kit will function identically to the factory system except for being louder and much more responsive.

2. Test drive the vehicle. Listen for odd noises or rattles and fix as necessary.

3. If road test is fine, you can now enjoy the added power and performance from your kit.

4. K&N Engineering, Inc., suggests checking the air filter element periodically for excessive dirt build-up. When the element becomes covered in dirt (or once a year), service it according to the instructions on the Recharger® service kit, part number 99-5050 or 99-5000