



AIRCHARGER™

HIGH-FLOW INTAKE KITS

INSTALLATION INSTRUCTIONS

63-1058
TOYOTA
2003-04 Tundra
V8-4.7L

NOTE: This kit was not designed to fit vehicles with a body lift.

TOOLS NEEDED:

- 2.5mm Allen Wrench
- 4mm Allen Wrench
- 10mm Socket
- 12mm Socket
- 10mm Wrench
- 5/8 Wrench
- 9/16 Wrench
- Flat Blade Screwdriver
- Long Extension
- Phillips Screwdriver
- Ratchet
- Side Cutters

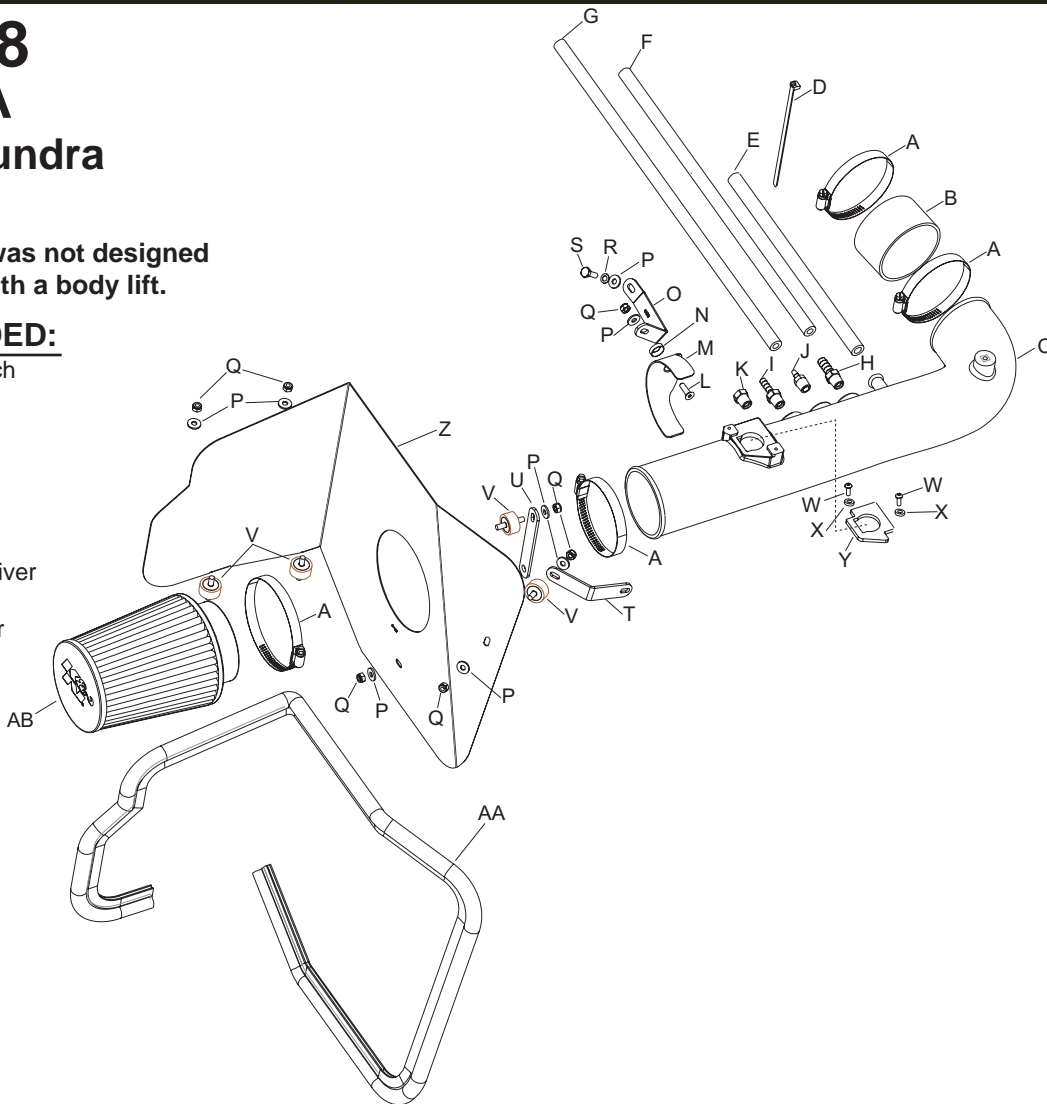

PARTS LIST:

Description	Qty.	Part #
A	4	08610
B	1	08690
C	1	087065
D	1	21591
E	1	087031
F	1	08153
G	1	08409
H	1	08908
I	1	08046
J	1	080021
K	1	08032
L	1	08376
M	1	078855
N	1	08180
O	1	070971
P	8	08275
Q	7	07553
R	1	08174
S	1	07863
T	1	070581
U	1	070979
V	4	07027
W	2	07793
X	2	06530
Y	1	09066
Z	1	07433
AA	1	102492
AB	1	RC-5100

NOTE: FAILURE TO FOLLOW INSTALLATION INSTRUCTIONS AND NOT USING THE PROVIDED HARDWARE MAY DAMAGE THE INTAKE TUBE, THROTTLE BODY AND ENGINE.

TO START:

1. Turn off the ignition and disconnect the negative battery cable.

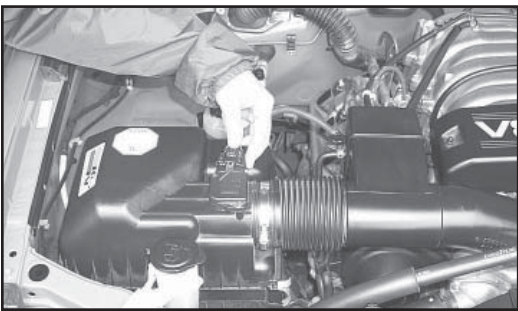

2. Disconnect the mass-air connection

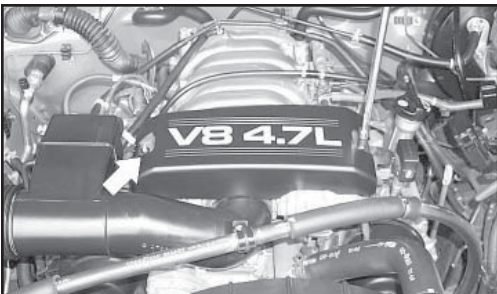

3. Loosen and remove the acorn nuts that secure the throttle body cover, then remove the cover.

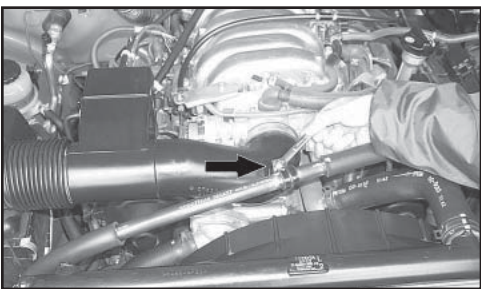

4. Loosen and remove the bolt that secures the AC line to the stock intake tube.

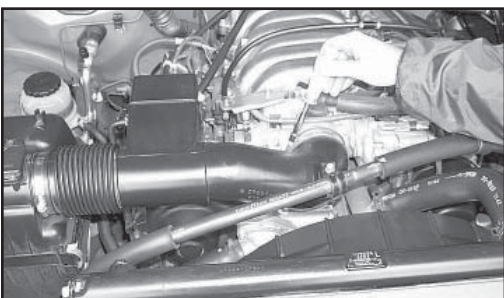

5. Loosen the hose clamp at the throttle body.

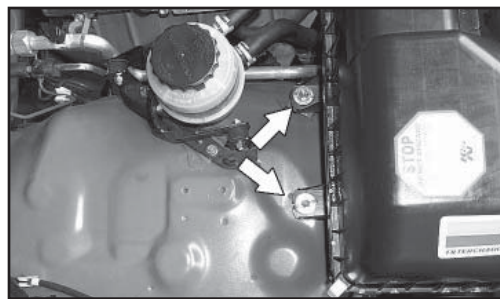

6. Loosen the three bolts that secure the air box assembly.

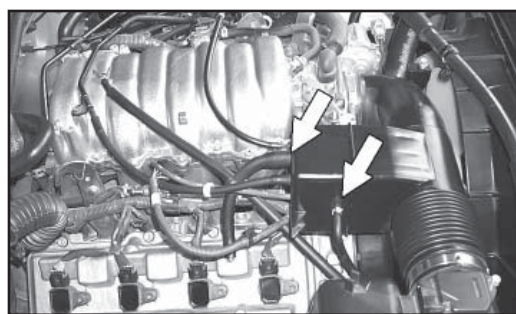

7. Disconnect the four rubber hoses from the engine as shown by the arrows.

NOTE: Some '03 models may come equipped with only three vacuum lines.

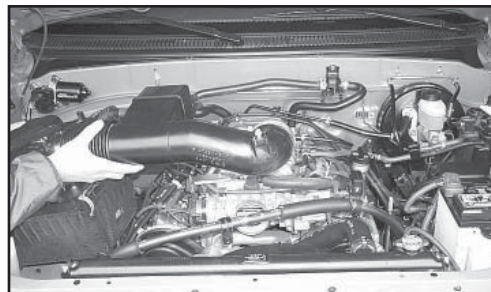

8. Remove the complete air induction system.
NOTE: K&N Engineering, Inc., recommends that customers do not discard factory air intake.

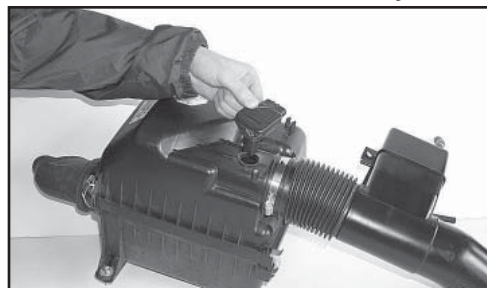

9. Loosen and remove the two screws that secure the mass-air sensor, then remove the mass air sensor.



10. Apply the provided gasket to the mass-air sensor with the sticky side down.

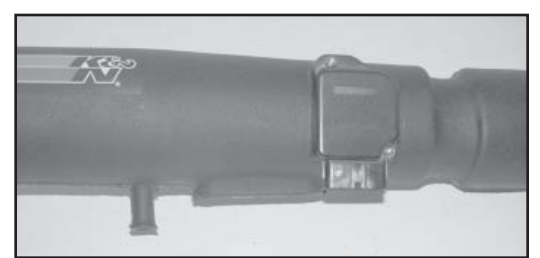

11. Install the mass-air sensor into the K&N® intake tube, and secure with the provided spacers and screws as shown.

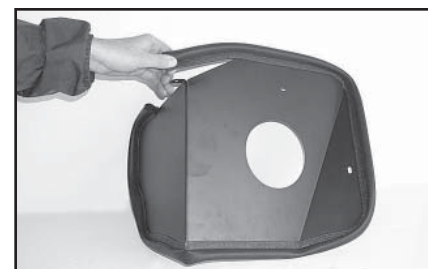

12. Apply the edge trim to the K&N® heat shield as shown above, trim if needed.



13. Install the two rubber mounted studs to the heat shield with the provided hardware, but do not tighten completely.



14. Secure the two brackets to the heat shield with the provided hardware, but do not tighten completely.

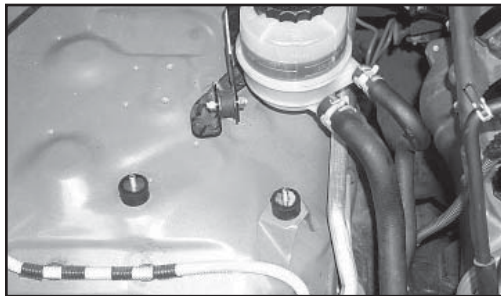

15. Install the two remaining rubber mounted studs to the original air box mounting holes.



16. Install the heat shield onto the rubber mounted studs as shown above.

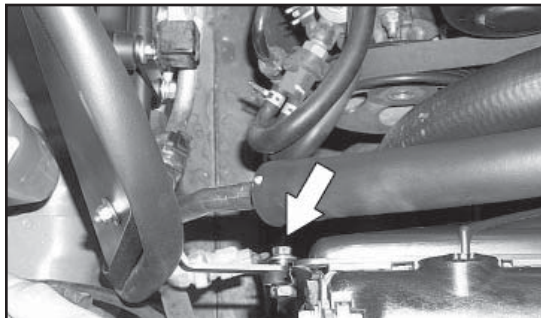

17. Secure the upper bracket to the fan shroud with the original bolt.

18. Secure the lower bracket to the inner fender well, using the original bolt.

19. Secure the heat shield tabs to the rubber mounted studs with the provided hardware.

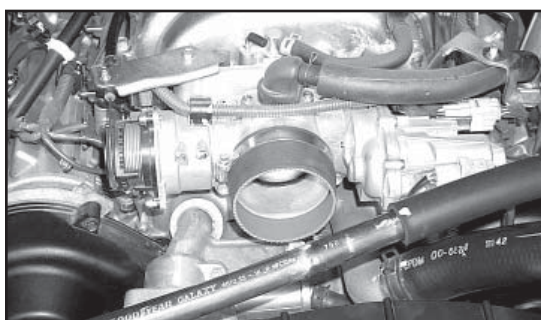

20. Install the silicone hose onto the throttle body and secure it with the provided hose clamp.

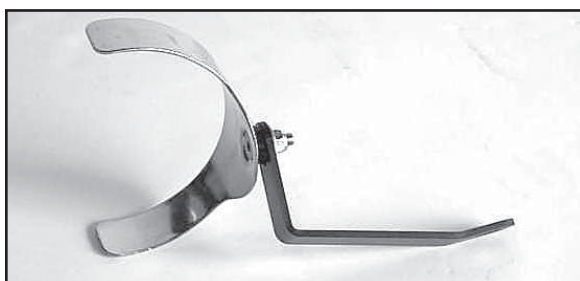

21. Assemble the saddle bracket assembly as shown above.



22. Install the saddle bracket assembly onto the existing threaded boss on the cam cover, do not tighten completely.



23. On 2000-02 models, install the three vents into the intake tube in the orientation as shown above.



23a. Some 03 models, install the two vents and plug into the intake tube in the orientation as shown above.

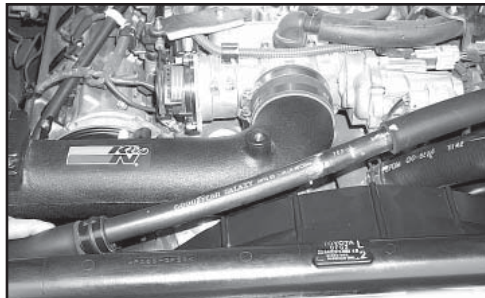

24. Install the K&N® intake tube onto the throttle body and secure with the provided hose clamp.



25. Secure the saddle bracket to the tube with the provided hose clamp.

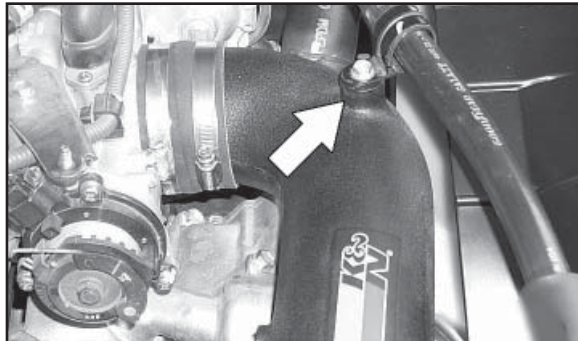

26. Re-connect the AC line to the K&N® intake tube using the original bolt.

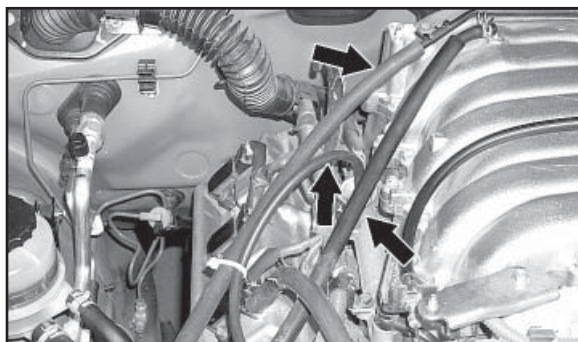

27. Install the three vent hoses onto the engine as shown above. (see arrows)

NOTE: Some '03 models may come equipped with only three vacuum lines.

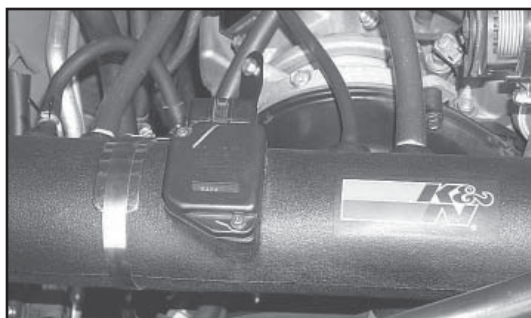

28. Attach the three provided, and one existing hose onto the K&N® intake tube as shown.
NOTE: Some '03 models may come equipped with a total of three vacuum lines.

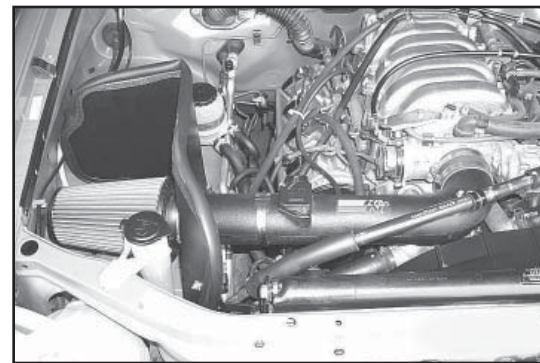

29. Install the K&N® air filter onto the K&N® intake tube as shown.

30. Tighten all brackets and bumper studs and check for proper clearances.

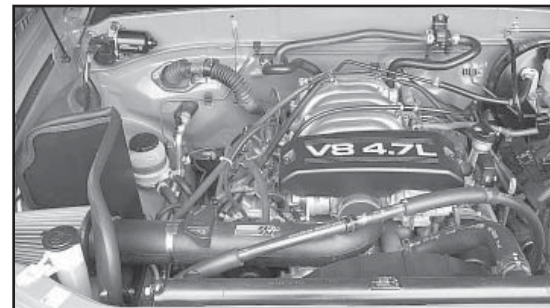

31. Re-install the throttle body cover onto the engine using the original acorn nuts.

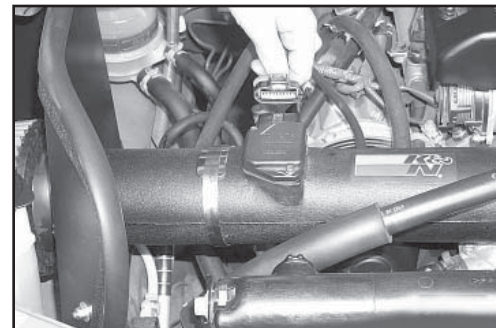

32. Re-connect the mass-air connection.

33. Reconnect the vehicle's negative battery cable. Double check to make sure everything is tight and properly positioned before starting the vehicle.

34. It will be necessary for all K&N® high flow intake systems to be checked periodically for realignment, clearance and tightening of all connections. Failure to follow the above instructions or proper maintenance may void warranty.

ROAD TESTING:

1. Start the engine with the transmission in neutral or park, and the parking brake engaged. Listen for air leaks or odd noises. For air leaks secure hoses and connections. For odd noises, find cause and repair before proceeding. This kit will function identically to the factory system except for being louder and much more responsive.

2. Test drive the vehicle. Listen for odd noises or rattles and fix as necessary.

3. If road test is fine, you can now enjoy the added power and performance from your kit.

4. K&N Engineering, Inc., suggests checking the air filter element periodically for excessive dirt build-up. When the element becomes covered in dirt (or once a year), service it according to the instructions on the Recharger® service kit, part number 99-5050 or 99-5000.