

USER GUIDE AND INSTALLATION MANUAL BEAR CLAWS LATCHES/INSTALL KITS

BCSM, BCLG, BCINST-S & BCINST-L

USER GUIDE

1. If applicable, remove door panel and original door latch mechanism.
2. Inspect the door shell to confirm the latch will clear all other parts, such as the door glass channel and door braces.
3. Determine new mounting position for AutoLoc™ Bear Claw Latch and Bear Claw Installation Kit.
4. Using new bear claw installation plate as template, cut out a new hole in door shell for the plate to be welded.
5. Double check clearance before welding is started.
6. Weld in AutoLoc™ Installation Plate to desired location.
7. Bolt in AutoLoc™ Bear Claw Latch to determine correct mounting of door striker.
8. Hook up all rods/cables for proper working interior/exterior door handles.
9. Using other installation plate for striker bolt, mark and cut out a new hole in door jamb.
10. Check that striker and bear claw latch will be able to align after all parts are tightened.
11. Weld in striker bolt mounting plate and bolt in striker bolt.
12. Shut door to test and align striker and latch for smooth shutting doors.

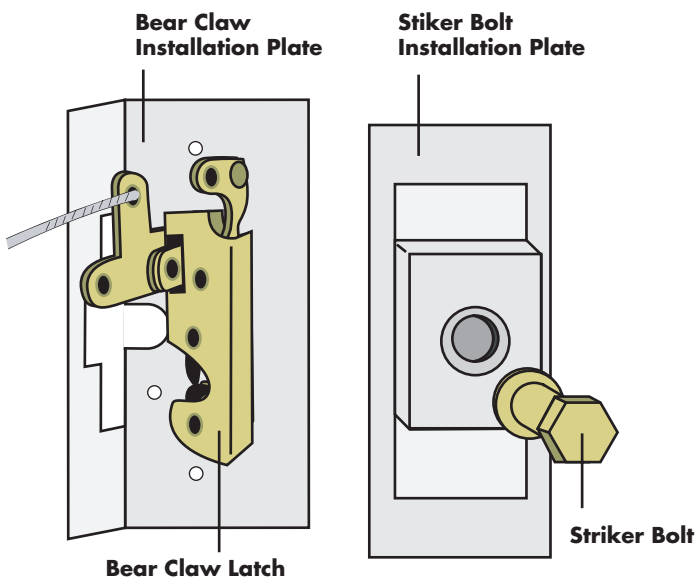

SPECIFICATIONS

BCSM - Small Bear Claw

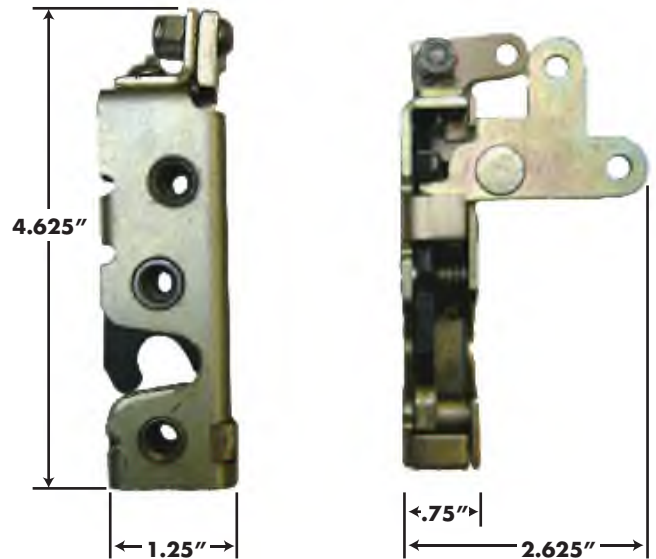

BCLG - Large Bear Claw

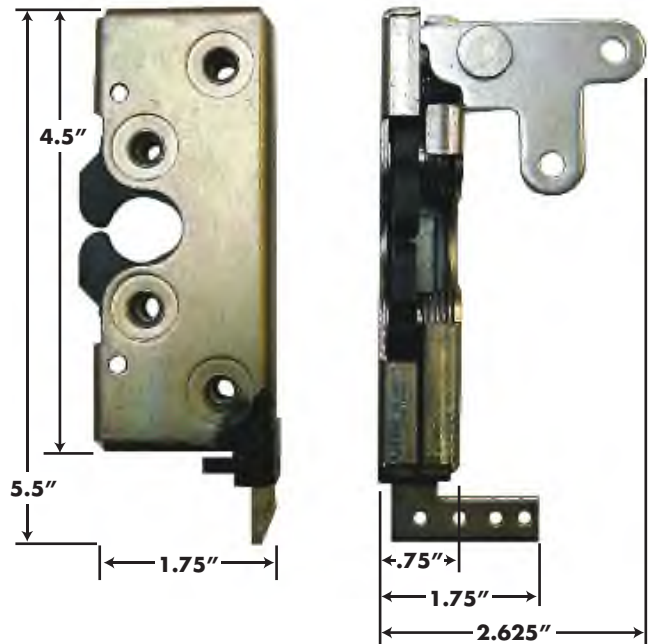

IMPORTANT NOTICE: Designed as universal kit. Kits requires cutting and welding skills. Contact Tech Support for any addition questions.